



DRIVE-E

A technology factsheet on Volvo Cars' powertrain technology
Model Year 2018





Contents

Drive-E – Powertrain Technology	3
---------------------------------	---

Modularity	4
------------	---

Petrol Engine Technology	5
--------------------------	---

- Advanced Boosting
- Supercharger and Turbos
- Advanced Combustion and Direct Injection
- Petrol Engines

Diesel Engine Technology	9
--------------------------	---

- Advanced Boosting
- Two-stage turbo
- PowerPulse
- Advanced Combustion and i-Art
- Diesel Engines

Transmissions	14
---------------	----

- 8-speed Automatic
- 6-speed Automatic
- 6-speed Manual – High Torque
- 6-speed Manual – Medium Torque

All-Wheel Drive (AWD)	16
-----------------------	----

Twin Engine (PHEV) Technology	17
-------------------------------	----

- Twin Engine Definition
- T8 Twin Engine – All Wheel Drive(AWD)
- T8 Twin Engine – Electric Real Axle Drive (ERAD)
- T8 Twin Engine – Crank-Integrated Starter Generator (C-ISG)
- T8 Twin Engine – High Voltage Battery
- Wallbox – Charging your Twin Engine

Powertrain Technology

“Volvo Cars’ Drive-E technology is all about delivering responsive power, clean efficiency and an **exceptional driving experience** with the latest powertrain technology and an a clear focus on electrification. By 2025 we will have up to one million electrified Volvos on the road, with our first fully electric car coming in 2019,” says Henrik Green, Senior Vice President Research & Development at Volvo Car Group.

Volvo Cars’ powertrain technology is based on the concept of efficient power, without compromise. Our modular approach to powertrain engineering means that our base engine architecture can deliver distinctive powertrain attributes and also be combined with driveline electrification on our new platform architectures, SPA and CMA.

Responsive Power

Our award-winning four-cylinder engines come with advanced boosting technology that delivers responsive power when desired through the innovative use of both turbo- and supercharging or through the instant electric torque of our advanced plug-in hybrid **Twin Engine** powertrains.

Our Drive-E technology delivers the performance and drivability expected by our customers.

Clean Efficiency

Drive-E powertrains are designed to reduce emissions. We have improved fuel efficiency by up to 35 per cent compared to our previous powertrain line-up, while also delivering weight savings of up to 45 Kg.

Volvo Cars launched the world’s first diesel plug-in hybrid in 2012. In 2014 we revealed the world’s cleanest and most powerful 7-seat plug-in hybrid SUV: the XC90 T8 **Twin Engine**. But this is just the beginning.



Electrification is the future

Volvo Cars is committed to electrifying its entire product line-up across its Compact Modular and Scalable Product Architectures. From 2019, all new Volvo models will be available with an electrified powertrain – from a mild hybrid 48-Volt system, through our **Twin Engine** plug-in hybrid to pure battery electric vehicles. We firmly believe that electrification and hybridization will play an increasingly significant role in the future of automotive propulsion by enabling increased driving pleasure and efficiency. Volvo Cars remains at the forefront of innovation in the field of powertrain engineering.

Modularity

One of the developmental principles and key benefits behind our award-winning Drive-E powertrains is that they were designed to reduce complexity by using a compact, modular approach.

This effectively means that both diesel and petrol models share a common architecture and can therefore be produced on the same lines in our engine plants.

The efficient design of the architecture also means that a broad range of engine power variants can be achieved with bolt-on power boosting turbo- and superchargers, coupled with bespoke engine software.

Petrol

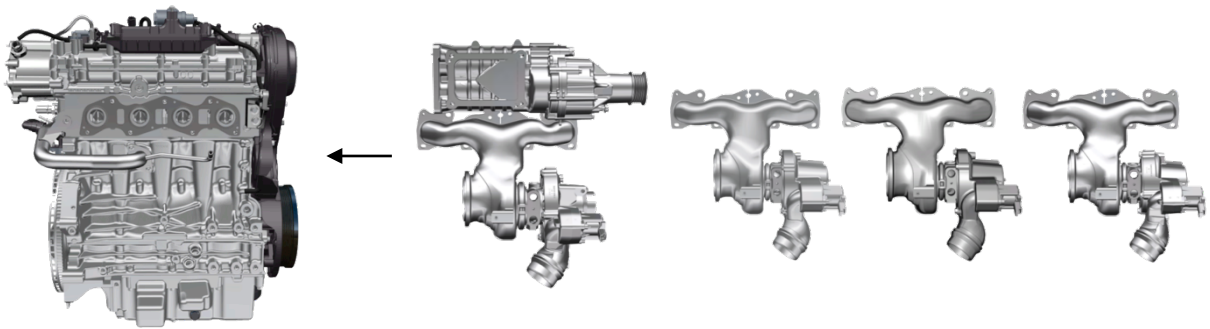

Diesel

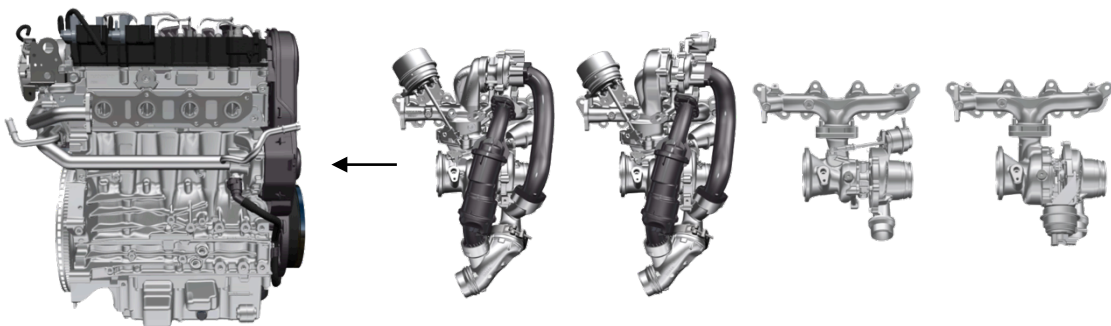

Petrol Engine Technology

Advanced Boosting

Volvo Cars has taken advanced boosting to a new level using a modular-based charging system that offers Volvo owners a range of power levels and engine performance attributes.

Advanced boosting means that our compact engines can deliver power levels equivalent to those of larger six- and eight-cylinder units with high torque availability across a wider speed range.

We use state-of-the-art charging systems consisting of turbochargers and superchargers designed to our precise specifications to deliver improved fuel economy, leading performance and drivability.

Supercharger and Turbos

Superchargers deliver low-end torque and response. Turbos deliver horsepower. Below 3500 rpm the supercharger and turbo are active.

Above 3500 rpm, only the turbo is applied. We use a large turbo combining low backpressure and high boost pressure capacity at high revolutions for maximum power output.

When combined, the supercharger and turbo charger deliver a smooth, consistent and compelling boost to our Drive-E powertrains.

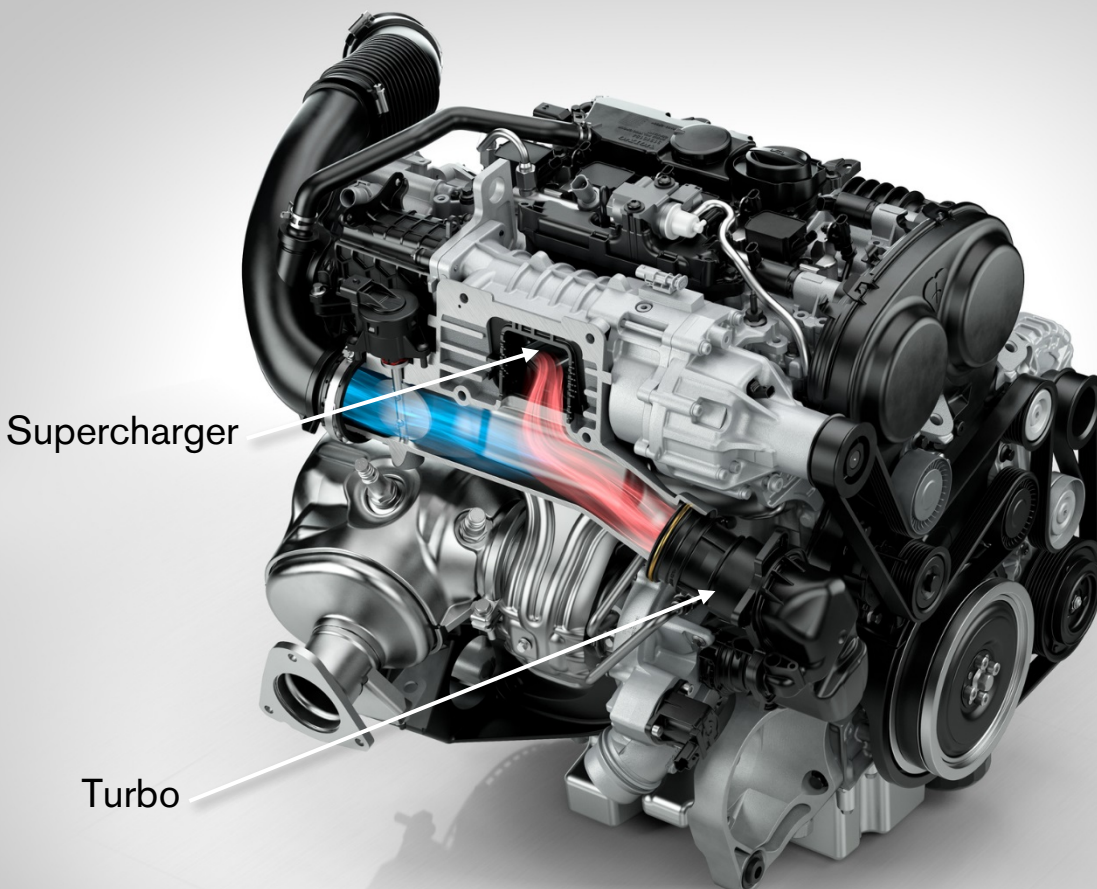

Petrol Engine Technology

Supercharger

Volvo Cars' electromagnetic clutch-operated supercharger is one of the fastest and the smoothest in production. It is currently used in the T6 powertrain configuration. The supercharger delivers 6-cylinder power when you want it and 4-cylinder fuel economy when you don't.



Volvo Cars has worked closely with Eaton to develop this unique electromagnetic clutch-based supercharger solution for its T6 Drive-E petrol engine. The electromagnetic clutch sits between the rotors and input shaft, delivering the low-end power of a 6-cylinder in Volvo's 4-cylinder Drive-E powertrains.

The intelligent algorithm created for the electronic control module (ECM), designed by Volvo's powertrain engineers, takes the art of advanced boosting to the next level.

When the engine is running at cruising speed the clutch remains open, disconnecting the belt drive from the rotor mechanism. The electromagnetic clutch is activated on demand by a signal from the ECU, when the driver requests acceleration by pressing the accelerator pedal, engaging the gears and spinning the supercharger rotors.

Harnessing torque reserve from the crankshaft while adding increased airflow and momentarily retarding the advance spark, enables a quicker supercharger ramp up when the electro-magnetic clutch is engaged. Combined with a now advanced spark, the supercharger delivers a reassuringly fast response. The smooth nature of Volvo's supercharger sets it apart from the competition with a coupling time of less than 350 milliseconds.

Once the engine has reached over 3000 rpm a butterfly valve in the intake opens and the clutch disconnects the supercharger as the turbocharger, now fully spooled by exhaust gases, kicks in.

As the supercharger only operates on demand, the pulley gearing ratio has been increased to almost seven-to-one (almost twice the conventional ratio), meaning that the supercharger, at peak, rotates at almost 24,000 rpm – making it one of the fastest superchargers in production.

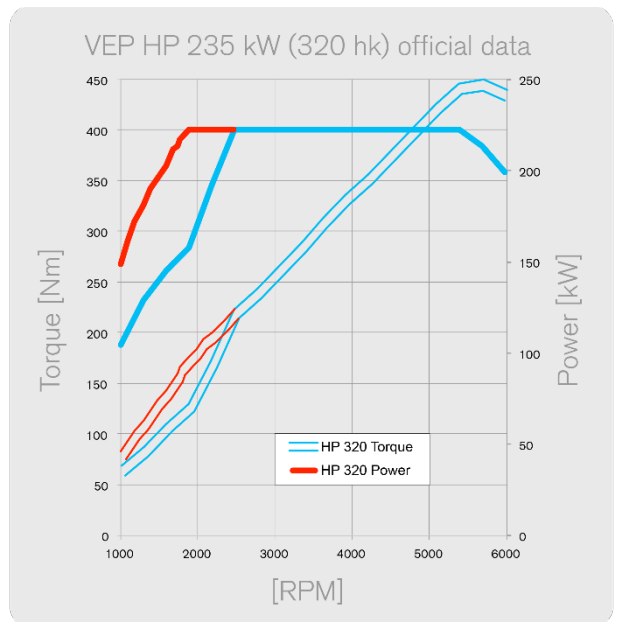

Petrol Engine Technology

Advanced Combustion

The combustion system designed for the petrol engines is comprised of a centrally mounted spark plug and injector with a unique spray layout that provides a homogeneous air-fuel mixture.

This central **direct injection** technique enables:

- Stratified start and an effective catalyst heating mode that outperforms Port Fuel Injection (PFI) and side mounted Direct Injection engines, resulting in low fuel consumption and enabling Euro6 and LEVIII emission compliance.
- Improved low-end torque compared with PFI by using scavenging and charge cooling by direct fuel injection.

The intake ports are designed to generate a high tumble motion, promoting the mixing of air and fuel during the intake stroke. In the succeeding compression stroke, this tumble motion is broken down into turbulence, accelerating the combustion speed. The combustion is therefore very stable, enabling a high degree of internal EGR, which minimizes pumping losses, hence reducing the fuel consumption. Special efforts were made to achieve a combustion system that is knock resistant. The cooling water jacket, intake ports, spray target and combustion chamber geometry were fine-tuned, enabling a fuel-efficient, high compression ratio of 10.8 for the gasoline T5 and 10.3 for the gasoline T6.



Petrol Engines

	T6	T5	T4	T3	T2
Displacement	2.0l	2.0l	2.0l	1.5l	1.5l
Charging system	One supercharger + one turbo with waste gate	One turbo with waste gate	One turbo with waste gate	One turbo with waste gate	One turbo with waste gate
Balancer shafts	Yes	Yes	Yes	No	No
Engine structure	Light weight high-pressure die cast aluminium crank cases and bedplates with cast-in iron liners and nodular cast iron bearing reinforcements.				
Crank system	Similar pistons i.e. forged steel crank shafts to minimise bearing sizes, different machining of the piston top for different compression ratios. Friction reduced by 50%, ring tangential load reduction with Physical Vapour Deposition-coating (PVC) on the top ring and new honing specification. Piston pins are coated with Diamond-like Carbon (DLC).				
Cylinder head	The T6 utilizes a double water jacket design to aid cooling and flow.	To cope with a very high heat load, ALSi7 aluminium alloy with T7 heat treatment was chosen. The T2, T3, T4 and T5 engines utilize a single water jacket design.			
Valve system	Direct-acting high-speed variable valve system with service-free DLC-coated mechanical tappets. Roller bearings on first cam bearing position to reduce friction. Cam phasers on both intake and exhaust camshafts enables flexibility in the trade-off between emissions, fuel consumption and drivability.				
Oil system <small>(with variable oil pump)</small>	The oil pump is fully variable and the oil pressure is controlled by a solenoid actuator for friction reduction.				
Cooling system / Thermal management	The petrol engines are equipped with a 400 W electrical water pump to reduce friction losses and create the possibility to control the coolant flow for fast engine warm-up and friction reduction.				
Combustion system	A centrally mounted spark plug and injector with a unique spray layout that provides a very homogeneous air-fuel mixture.				
Exhaust gas after-treatment	Volvo Car's exhaust gas after-treatment system (three way catalytic converter, particulate filter*) shows very low pressure drop and high uniformity qualities and shares a similar base design for both petrol and diesel applications, capable of fulfilling all applicable requirements				

* System roll-out starts 2017

Petrol Engines

T6 Rear

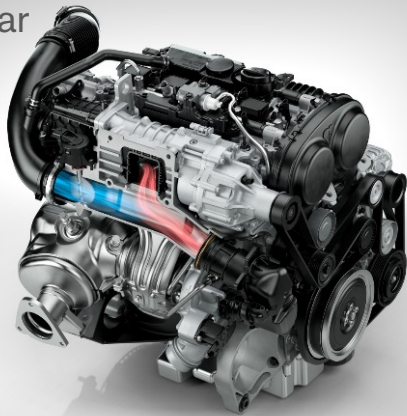

T6 Front



T5 Rear

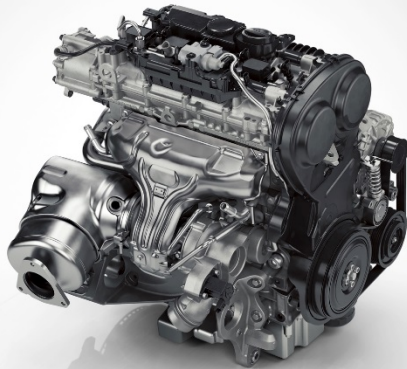

T4/T3/T2 Rear



Diesel Engine Technology

Advanced Boosting

Volvo Cars' modular approach to advanced boosting also applies to the diesel engines in the Drive-E powertrain line-up.

Consisting of a **serial sequential two-stage** turbo system, it is based on a refined version of the boosting technology first introduced in Volvo cars in 2008.

Once again, advanced boosting enables the delivery of increased power and drivability, but with lower fuel consumption. The two-stage turbo also allows both low and high-speed response.

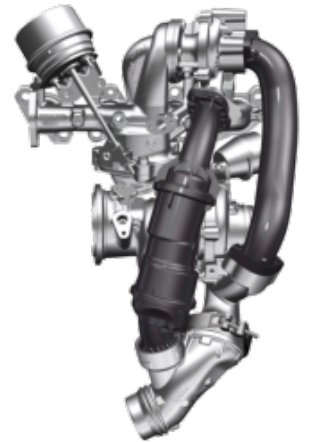

Two-stage Turbo (D4)

Two-stage Turbo

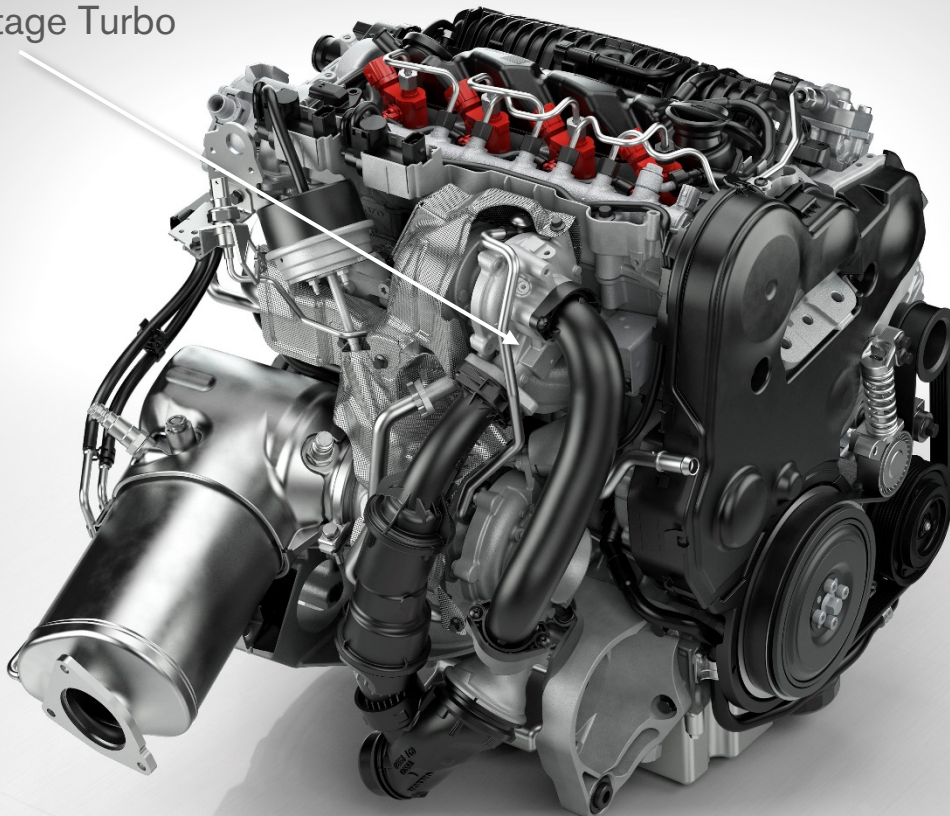

PowerPulse

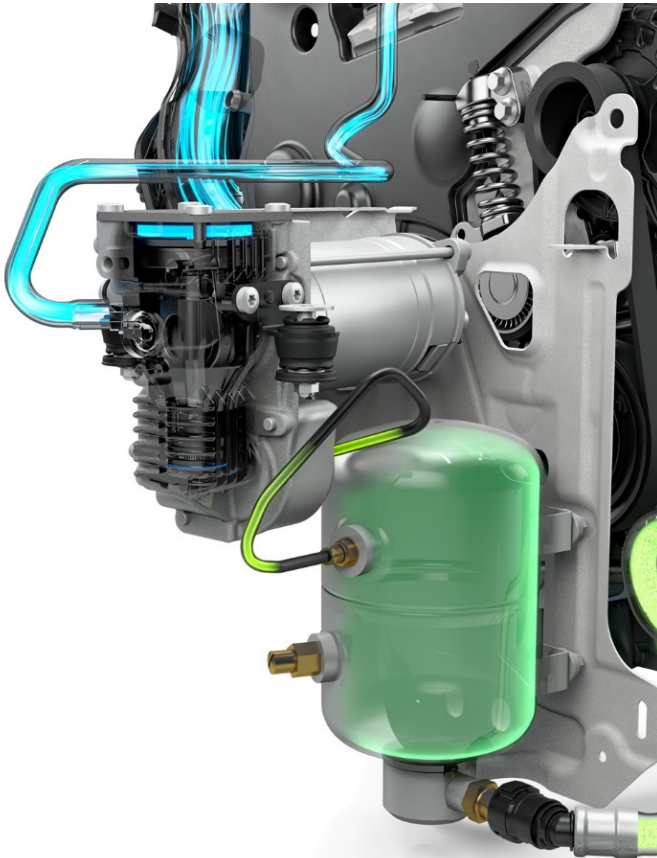

With PowerPulse, Volvo Cars has developed an innovative way of delivering instant turbo response in diesel engines providing a distinct performance feel that many car makers struggle to achieve in their diesel variants.

PowerPulse works by drawing air from the air filter via a compressor to a pressurised two-litre air tank.

When the driver wishes to accelerate quickly during launch and during low-speed driving, the air is fed by a valve into the exhaust manifold to feed the turbo. This has the effect of delivering a quick and responsive pulse of power.

The air in the tank is topped-up automatically, making sure that PowerPulse is always ready to deliver a new boost.

Volvo Cars is the first car maker using such technology in production cars.

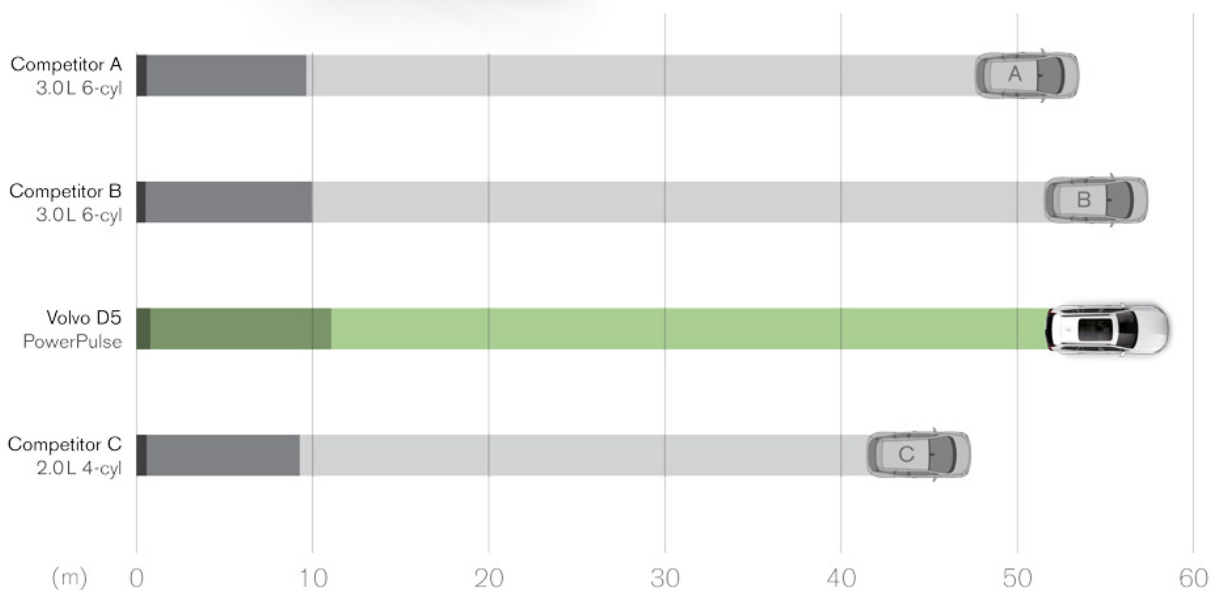

Diesel Engine Technology

Advanced Combustion

i-Art represents the latest diesel fuel system technology.

The system rail pressure of up to 2,500 bar is increased compared to previous systems of 1800 to 2000 bar. Thanks to a pressure sensor and an intelligent chip in each injector, it is possible to get vast and accurate feedback, resulting in much improved control of the injected fuel quantity.

This accurate and compensating injection system delivers up to 9 injections per combustion for precise combustion control. As each injector responds to real-time changes in its cylinder it means that the constantly variable injection can compensate for variations due to production and aging of the system.

This precise control of the combustion cycle means that consumption can be balanced to meet state of the art attribute levels and deliver up to 2 percent improved fuel efficiency. Volvo Cars was the first European car maker to introduce i-Art Technology in its cars.

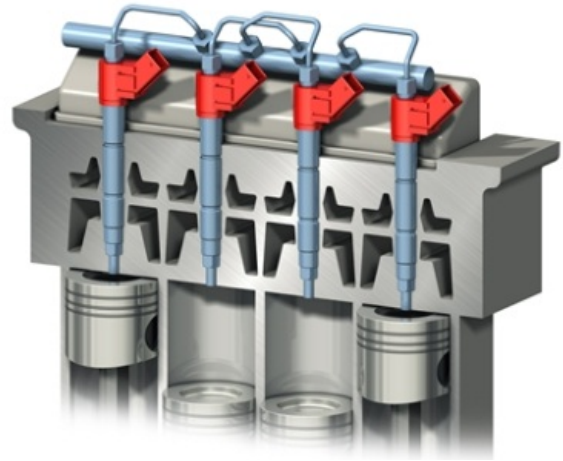
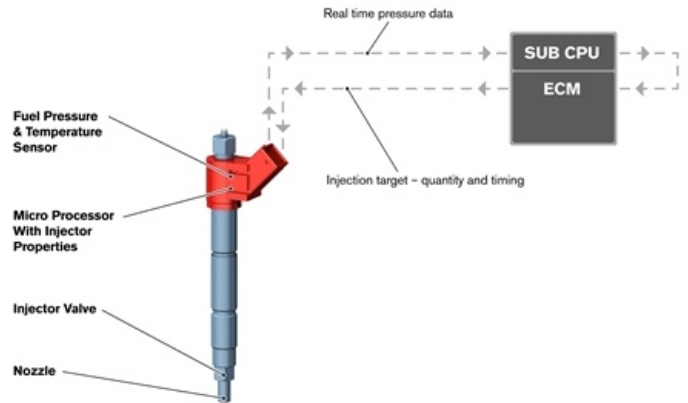

Irregular combustion (without i-Art)

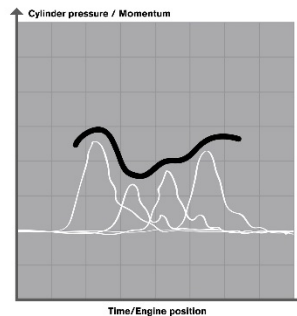

i-Art combustion - controlled and optimised

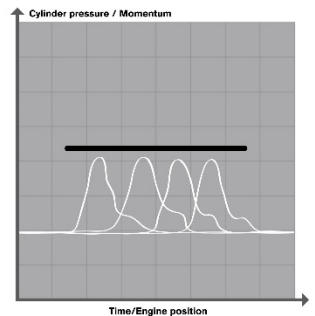

Diesel Engines

	D5	D4	D3	D2
Displacement	2.0l	2.0l	2.0l	2.0l
Charging system	Series-sequential two-stage turbo with one VNT	Series-sequential two-stage turbo	One VNT turbo	One turbo with waste gate
Balancer shafts	Yes	Yes	No	No
Engine structure	High-pressure die cast aluminium crank cases and bedplates with cast-in iron liners and modular cast iron bearing reinforcements.			
Crank system	Forged steel crank shafts to minimize bearing sizes. Friction reduction, 50% ring tangential load reduction with Physical Vapour Deposition-coating (PVC) on the top ring and new honing specification. Piston pins are coated with Diamond-like Carbon (DLC) + common design of the ring pack. The result is improved efficiency through friction reduction.			
Cylinders	Piston with cooled ring carrier for optimal cooling performance.		Light weight piston with a reduced compression height, longer and lighter con-rod and smaller piston pin diameter. Reduce oscillating mass by 20%	
Cylinder head	Transverse cooling concept gives excellent and even cooling performance. To cope with a peak firing pressure of 190 bar and high specific power, the coolant cores and the supporting structure for the fire deck were designed with great care. A new heat treatment was developed to improve the material strength and temperature limit. Forced air quenching is used to minimise residual material stress. This results in a significantly improved microstructure, with dendrite ARM spacing of less than 17 um. The material specification is A319 T7.			
Valve system	A classic roller finger follower valve system with hydraulic lash adjusters and steel-built camshafts for reduced weight and material hardness for the rolling contact. Positioning pins to the camshaft bearing caps assure alignment during machining and assembly, reducing friction.			
Oil system (with variable oil pump)	The oil pump is fully variable and the oil pressure is controlled by a solenoid actuator for friction reduction.			
Cooling system/ Thermal management	The outer cooling system is different for petrol and diesel cars because diesel engines have higher heat rejection at full load and lower heat rejection at part load and during warm-up. The diesel engines use a mechanical water pump. Heat transfer to the climate system is achieved through a separate electric pump. Efficient thermal management improves fuel economy and cabin comfort.			
Combustion system	The fuel injection system for the Drive-E diesel engines is a world first, with the combination of 2500 bar maximum injection pressure and closed-loop fuel quantity control, called intelligent Accuracy Refinement Technology (i-ART).			
Exhaust gas after-treatment	Volvo Car's exhaust gas after-treatment system (LNT, particle filter and selective catalytic reduction*) shows very low pressure drop and high uniformity qualities and shares a similar base design for both petrol and diesel applications, capable of fulfilling all applicable requirements			

Diesel Engines

D5 Rear

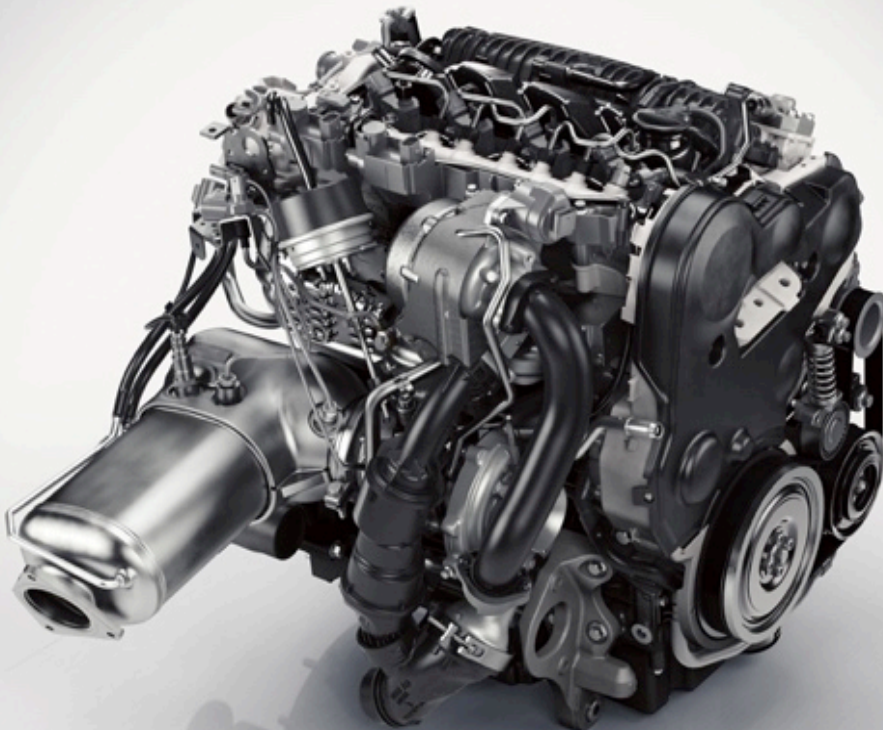

D4 Rear



D3/D2 Rear



Transmissions

Automatic

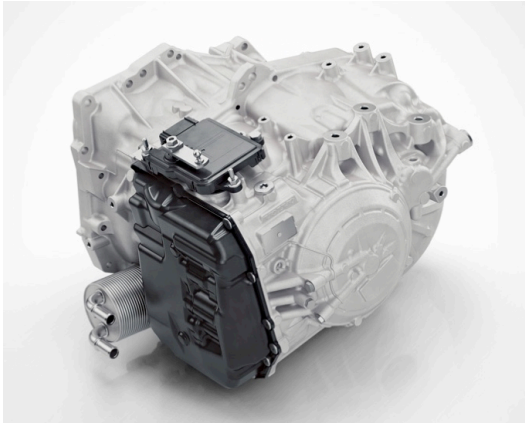

8-speed Automatic

- Best in class efficiency
- Quick and smooth shifting
- Converter technology for powerful launches
- High torque capacity combined with small size and low weight
- Start-stop technology (electric oil pump keep transmission ready for re-start)

The Volvo eight-speed planetary automatic transmission is a vital part of Drive-E powertrain technology. The number of gears means that the engine's torque and power band can be utilized more efficiently.

Two of the gears are 'overdrives', which save fuel when cruising at constant speeds.

The lock-up system is comprised of the latest NVH damping technology (pendulum damper for diesels and super long travel damper for the petrol engine). This enables frequent use of the lock-up and allows the engine to run on low revs for best fuel economy.

The T8 Twin Engine variant has a unique engine-braking mode. The maximum torque level is also increased to enable better use of the C-ISG for performance boosting purposes.

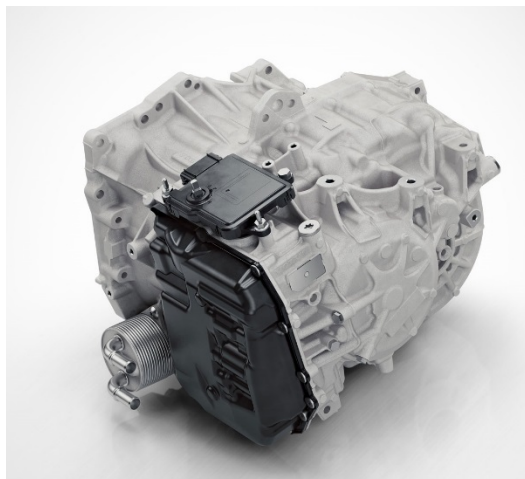

6-speed Automatic

- Best in class efficiency
- Quick and smooth shifting
- Converter technology for powerful launches
- Start-stop technology (electric oil pump keep transmission ready for re-start)

The Volvo six-speed planetary automatic transmission is a vital part of Drive-E powertrain technology for medium torque powertrains.

The six-speed transmission shares the same technology as the eight-speed transmission. The difference is the number of speeds and the adaptation for medium torque levels.

Transmissions

Manual



6-speed Manual - High Torque

- 450Nm transmission
- Light weight ~54 kg
- New optimized gear sets and final drives to provide good drivability and fuel economy

This manual gearbox is a new generation of our well proven six-speed manual gearbox. New gear sets and efficiency work have made it smoother and even more fuel efficient. Combined with the new external shifter design, the gear positions are more exacting and solid.

This gearbox will also be available in an All-Wheel Drive application for products based on our Scalable Product Architecture (SPA).



6-speed Manual - Medium Torque

- 330Nm transmission
- Light weight ~42 kg
- Optimized gear sets and final drives to provide good drivability and fuel economy

This is a new manual transmission developed for Volvo Cars' medium torque applications. Excellent shifting is achieved thanks to low internal inertia and a new shifting mechanism. A huge improvement made on torque to weight ratio has been achieved with this new transmission.

All Wheel Drive



ALL WHEEL DRIVE

The all-wheel drive variants have a very efficient type of four-wheel drive system. A compact and lightweight coupling (BorgWarner Gen. 5) distributes the engine's power between the front and rear wheels. Under normal, dry conditions practically all of the power is distributed to the front wheels. The system constantly calculates the need for torque to the rear wheels and can instantly redistribute up to 50 per cent of the engine's torque to the rear wheels. When at a standstill, full all-wheel drive is always engaged to prepare for maximum traction during acceleration.

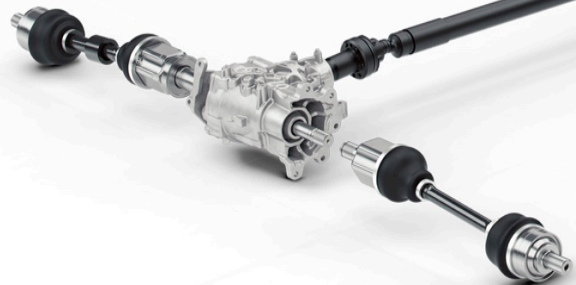

Twin Engine Technology

Plug-in hybrids

“We have made a clear commitment to electrification across the entire product range. Our Twin Engine technology delivers a no compromise balance of clean, efficient performance and exceptional driving pleasure. It is a confident step forward on the journey to increased electrification,” says Henrik Green, Senior Vice President Research & Development at Volvo Car Group.

PURE



HYBRID



POWER



Twin Engine Definition

Volvo's Twin Engine technology is essentially a combination of an internal combustion engine and electric power. Electric energy from the grid can be stored in a High Voltage Battery. The technology is more commonly known as Plug-in Hybrid Technology (PHEV).

Volvo's technology is designed to deliver three cars experiences in one.

- **PURE** – where the car runs on electric power alone.
- **HYBRID** – where an optimal combination of the engine and electric machine propels the cars in a balanced and sustainable way.
- **POWER** – where all available power is used to deliver maximum performance.

Volvo's Twin Engine set-up means that the high voltage battery is positioned in the tunnel console for maximum safety and also improved weight distribution that gives an improved driving experience.

Twin Engine technology delivers a no compromise mix of performance, driving pleasure, efficiency interior, cargo space and flexibility.



T8 Twin Engine Technology

All Wheel Drive

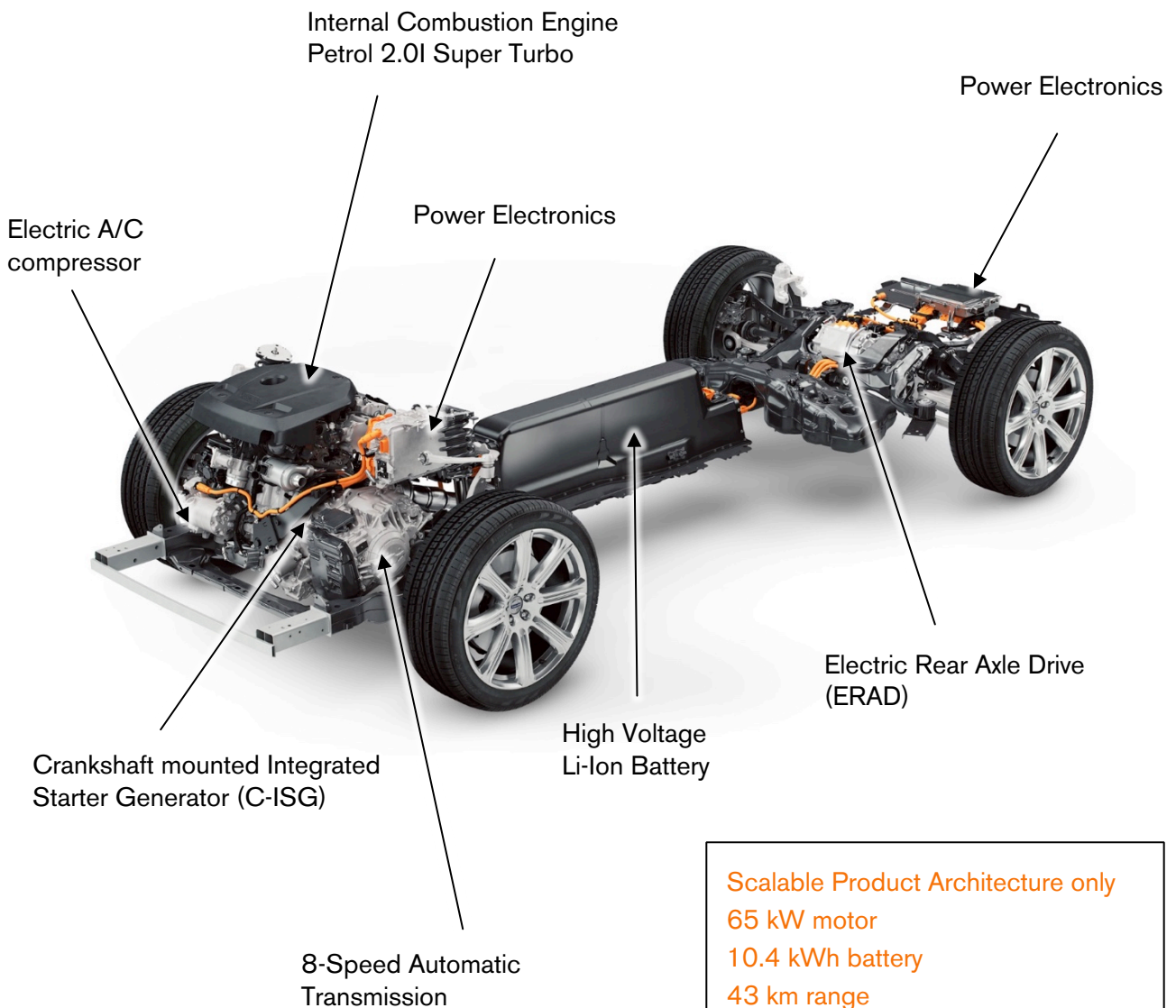

Scalable Product Architecture only
65 kW motor
10.4 kWh battery
43 km range

T8 Twin Engine Technology

All Wheel Drive

- Propels vehicle in electric mode
- Provides electric boost torque and power during acceleration
- Provides electric all wheel drive functionality
- Performs brake energy recuperation



Permanent Magnet Synchronous Machine

Peak power: 65 kW

Peak torque 240 Nm

Weight: 34 kg

Cooling: Water cooled stator

T8 Twin Engine Technology

Crank-Integrated Starter Generator

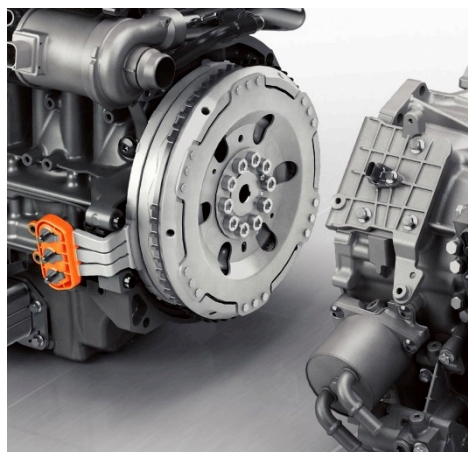

- Charges the battery
- Starter for the combustion engine
- Can support the combustion engine with electric boost power

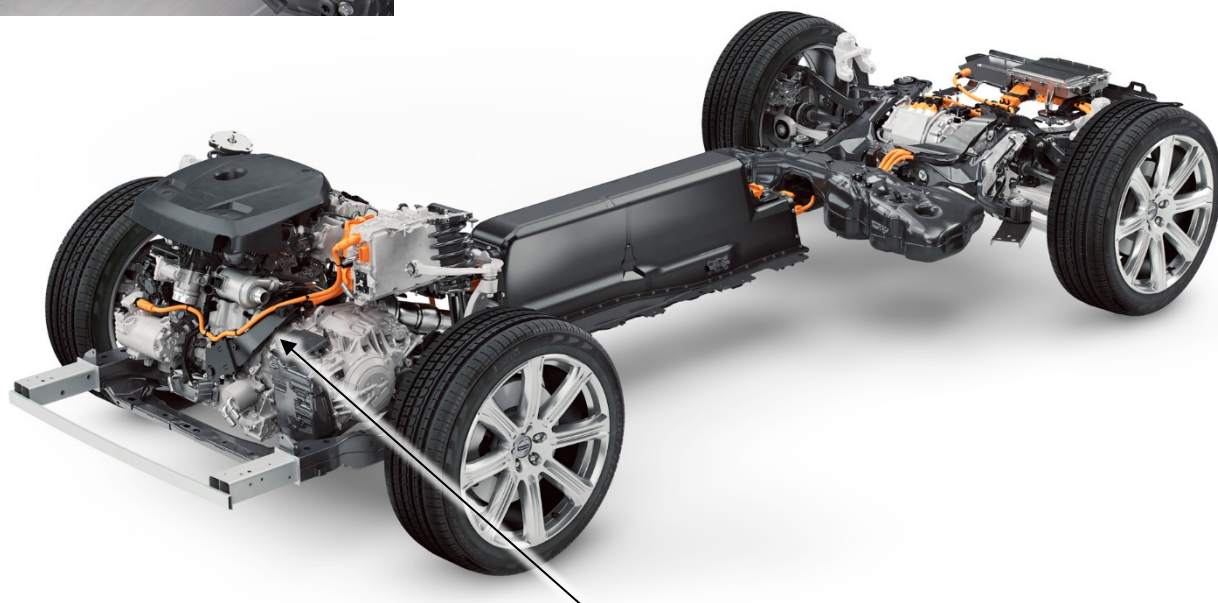

Permanent Magnet Synchronous Machine

Peak power: 34 kW

Peak torque: boost 150 Nm, cold crank = 180 Nm 240 Nm

Weight: 18kg

Cooling: Water cooled

T8 Twin Engine Technology

High Voltage Battery

The function of the high voltage battery is to store energy. It receives energy from electric grid charging and also from regenerative braking of the vehicle or from the C-ISG.

The high voltage battery delivers power for pure electric drive and also to run the electric air conditioning for pre-climatisation of the passenger compartment.



Charging your Twin Engine

Introducing the Wallbox charging station

Volvo Cars' new Wallbox enables simple, safe and efficient charging for your Volvo Twin Engine-powered car. It reflects Volvo's commitment to making electric propulsion an everyday reality and commitment to having over one million electrified Volvos on the road by 2025.

Simple, safe, efficient

Designed for use with Volvo Cars' plug-in hybrid Twin Engine cars, Volvo's unique and stylish charging solution has been developed with safety, efficiency and simplicity at its heart.

Utilizing a pulsating LED light ring that is illuminated when connected to the car, the Wallbox includes an integrated 7.5 meter charge cable and holder.



Professional installation

The Volvo Wallbox is installed by certified electricians and uses 16A (3.7 kW) one-phase current in EU and two-phase in the US.

The Wallbox can be used with a variety of car brands and models, thanks to its industry standard connectors.

Twin Engine Technology

Plug-in hybrids

Currently in production

Powertrain	T8 Twin Engine AWD	T6 Twin Engine AWD	D5 & D6 Twin Engine AWD
Vehicles	XC90, S90, V90, XC60	S60L	V60
Markets	Global *	China	Europe
Internal Combustion Engine	Petrol In-line 4-cyl Super & turbocharged	Petrol In-line 4-cyl turbocharged	Diesel In-line 5-cyl turbocharged
Battery	Li-Ion	Li-Ion	Li-Ion
Electric rear motor	Permanent Magnet Synchronous Machine	Permanent Magnet Synchronous Machine	Permanent Magnet Synchronous Machine
Transmission	8-speed automatic	8-speed automatic	6-speed automatic
Integrated Starter Generator	Crankmounted with EI-boost	Crankmounted with EI-boost	Belt driven
Charging Time (3.7kW 16A 230V)	2,5 h	3,5 h	3,5 h
Pre-climatisation Hot & Cold	Yes	Yes	Yes
Active and Passive AWD	Yes	Yes	Yes

** Volvo Cars' Twin Engine technology is being rolled out globally based on market demand and model availability. Please check with your local market representative for local offer details.*

DRIVE-E

Efficient Power, No Compromise



V O L V O

Published by Volvo Car Group © 2015. All rights reserved. Drive-E factsheet, September 2017