

Volvo S60 Cross Country

ENGINE

Type
Configuration
Displacement, cm ³
Bore (mm)
Stroke (mm)
Engine cylinder block material
Cylinderhead material
Compression ratio
Valves, no/cylinder
Camshafts
Engine management system
Ignition sequence
Engine idling speed, rpm
Fuel, rec. octane
Max output, kW (hp)/rpm
Max torque, Nm/rpm

T5 AWD (B4204T11)

In-line 4-cyl. turbocharged
Transverse, all wheel drive
1969
82.0
93.2
Aluminium
Aluminium
10.8:1
4
2
Gasoline direct injection
1 - 3 - 4 - 2
850±100
95-98 RON
180 (245)/5500
350/1500-4800

POWER AND TORQUE →

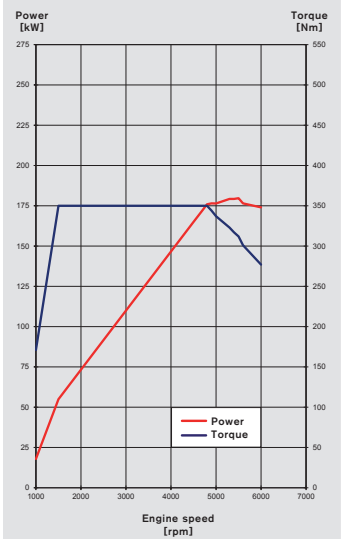

Manual gearbox/final drive
Automatic gearbox/final drive
PERFORMANCE
Gearbox
Acceleration, 0-100 km/h (sec)
Top speed, km/h
Fuel consumption l/100 km (combined)
CO ₂ g/km

-	
AW TG-81 SC	3.329
Automatic	
6.7	
210	
7.4	
168	

TRANSMISSIONS

- 6-speed manual gearbox
- 6-speed automatic transmission
- 8-speed automatic transmission

RATIO	M66F	AW TF -80SD	AW TG -81SC
First	3.583	4.148	5.250
Second	2.050	2.370	3.029
Third	1.267	1.556	1.950
Fourth	0.838	1.155	1.457
Fifth	0.617	0.859	1.221
Sixth	0.510	0.686	1.000
Seventh	-	-	0.809
Eighth	-	-	0.673
Reverse	2.833	3.394	4.015

ENGINES

Type
Configuration
Displacement, cm ³
Bore (mm)
Stroke (mm)
Engine cylinder block material
Cylinderhead material
Compression ratio
Valves, no/cylinder
Camshafts
Engine management system
Ignition sequence
Engine idling speed, rpm
Fuel
Max output, kW (hp)/rpm
Max torque, Nm/rpm

POWER AND TORQUE →

Manual gearbox/final drive
Automatic gearbox/final drive
PERFORMANCE
Gearbox
Acceleration, 0–100 km/h (sec)
Top speed, km/h
Fuel consumption l/100 km (combined)
CO ₂ g/km

D3 (D4204T4)
In-line 4-cyl. turbo diesel
Transverse, front wheel drive
1969
82.0
93.2
Aluminium
Aluminium
15.8:1
4
2
Electronically controlled common rail direct injection
1 - 3 - 4 - 2
825±150
Diesel*
110 (150)/4250
350/1500–2500

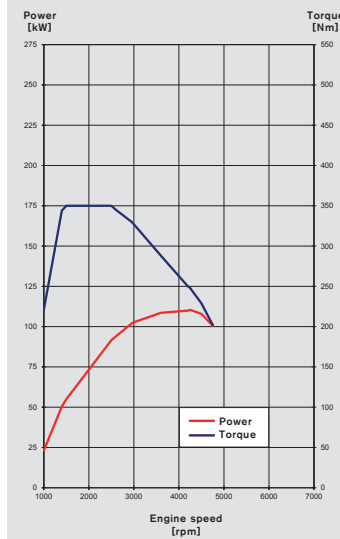

M66F	4.267
AW TG-81SC	2.839
Manual	Automatic
9.1	9.1
205	205
4.2	4.6
111	120

*According to EN590
Maximum biodiesel (FAME) content 7%

D4 (D4204T14)
In-line 4-cyl. twin turbo diesel
Transverse, front wheel drive
1969
82.0
93.2
Aluminium
Aluminium
15.8:1
4
2
Electronically controlled common rail direct injection
1 - 3 - 4 - 2
825±150
Diesel*
140 (190)/4250
400/1750–2500

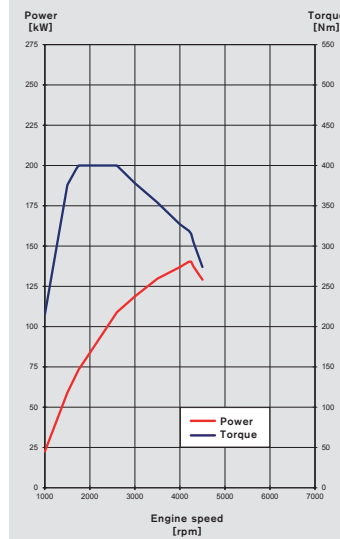

M66F	4.267
AW TG-81SC	2.839
Manual	Automatic
7.7	7.7
210	210
4.2 (4.2**)	4.6
111 (110**)	120

*According to EN590
Maximum biodiesel (FAME) content 7%
** Restricted offer

D4 AWD (D5244T21)
In-line 5-cyl. twin turbo diesel
Transverse, all wheel drive
2400
81.0
93.2
Aluminium
Aluminium
16.5:1
4
2
Electronically controlled common rail direct injection
1 - 2 - 4 - 5 - 3
740±25
Diesel*
140 (190)/4000
440/1500–2750

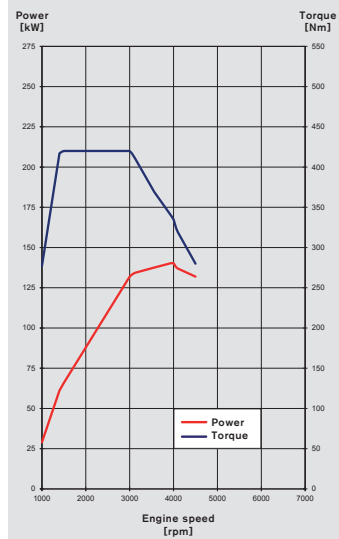

-	
AW TG-81SD	3.329
	Automatic
	8.8
	210
	5.7
	149

*According to EN590
Maximum biodiesel (FAME) content 7%

MEASUREMENTS AND VOLUMES

EXTERIOR MEASUREMENTS (CM)

Length	463.7
Width (body width)	182.5
Width (incl mirrors outer edge)	209.7
Height (including shark fin antenna)	153.9
Wheelbase	277.4
Track, front, (tire width) 215/235	161.9/160.9
Track, rear, (tire width) 215/235	157.7/156.7
Ground clearance	20.1

WEIGHTS/MISCELLANEOUS

Weight, kg (min-max, depending on setup)	1722-1745
Fuel tank, l	67.5
Max. trailer weight, kg	1800-1900
Max roof load, kg	75
Drag coefficient, Cd	0.28

INTERIOR MEASUREMENTS (CM)

Headroom without sunroof (front/rear row) (H61 SR/H63 SR)	97.3/95.1
Headroom with sunroof (front/rear row) (H61/H63)	95.5/95.1
Headroom maximum, without sunroof (front) (H63-1)	99.9
Headroom maximum, with sunroof (front) (H62-1 SR)	98.0
Passenger comp width at shoulder height (front/rear) (W3/W4)	144.7/140.1
Leg room (front/rear row) (L34/L51)	106.4/85.2
Cargo volume, including under floor storage (ISO V210) (litres)	380
Cargo length at floor from the back of front seatback (L212-1)	174.9
Cargo length at floor from the back of the rear seatback (L212-2)	96.5
Cargo floor height to ground (H253)	59.5
Loading height between cargo floor and parcel shelf (H212)	49.2
Liftover height (H196)	71.8
Width of luggage compartment between wheelhouses (W202)	91.9
Rear opening width at floor, min (W207)	95.6

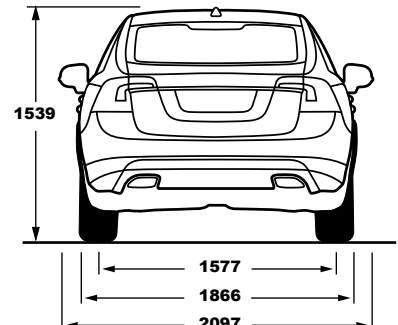
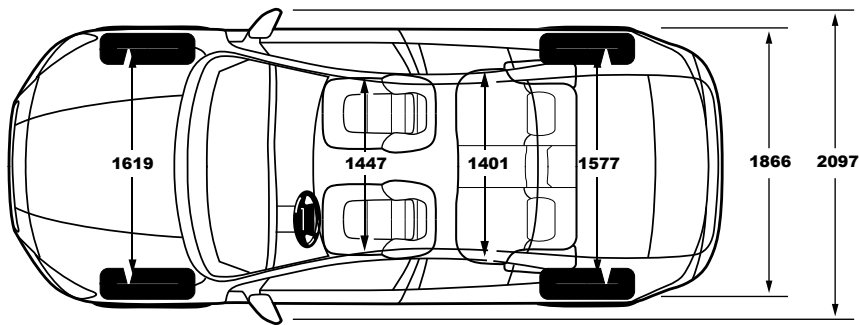
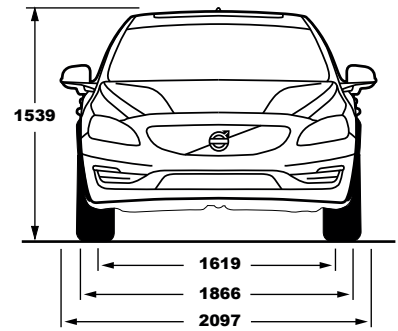
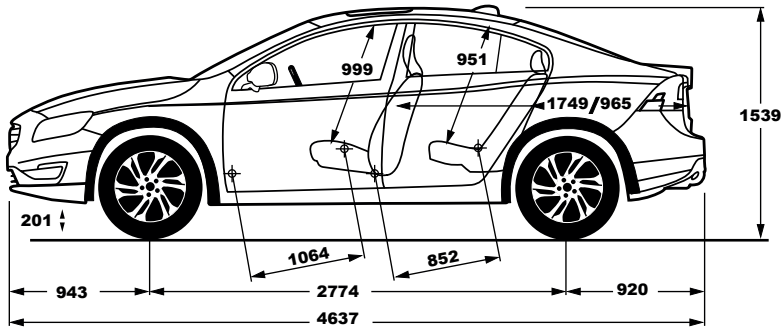

CHASSIS

Suspension	front	McPherson Strut, Coil Springs, Hydraulic Shock Absorbers, Stabilizer Bar
	rear	Trailing arm with Coil Springs, Hydraulic Shock Absorbers, Stabilizer Bar
Steering		Power Assisted Rack and Pinion Steering
Turning circle, (curb to curb)		11.4 m
Braking system		Antilock Braking System (ABS) with Electronic Brake Distribution (EBD) and Brake Assistance (BA) + Hill Descent Control (HDC)
Braking distance, 100-0 km/h		37 m
Brake disc diameter	front	316 mm
	rear	302 mm