

InCoax shows how shared 5G FWA can reach every apartment using existing coax

InCoax Networks AB highlights how shared 5G mmWave Fixed Wireless Access can become a practical broadband deployment model for multi-dwelling units when combined with MoCA Access over existing in-building coaxial infrastructure. By using 5G FWA as high-capacity backhaul to the property and InCoax’s platform to distribute that capacity to individual apartments, operators can accelerate broadband availability in dense urban buildings without full in-building rewiring.

Five years into 5G, mmWave remains one of the clearest examples of the gap between technical promise and everyday broadband value. The technology can deliver very high capacity in trials and targeted deployments, but it has not become the broad breakthrough many expected.

That may be because the industry has been looking for the wrong application. High-band 5G is not ideal for wide-area coverage or deep indoor reach through walls, low-emissivity windows and floor slabs. Its strength is high capacity over short distances, especially where demand is concentrated.

That makes fixed wireless access one of the most relevant roles for 5G mmWave. In dense urban areas, where many homes are concentrated within a small footprint and civil works can be costly or slow, mmWave FWA can bring multi-gigabit capacity to buildings faster than a full fiber build.

The recent U.S. auction of 5G spectrum underlines that licensed wireless capacity remains strategically important. But more spectrum alone does not create broadband services. Operators also need a cost-effective way to carry capacity from the building entry point to each subscriber.

This is the deployment gap InCoax is addressing. Reaching the building is not the same as connecting the apartments inside it. New fiber or Ethernet inside an existing MDU can be expensive, time consuming and disruptive for residents.

InCoax uses the coaxial infrastructure already present in many MDUs as a managed broadband access network. Its MoCA Access-based platform carries capacity from the building entry point to individual apartments, supporting per-subscriber separation, quality of service and operational control without new in-building cabling.

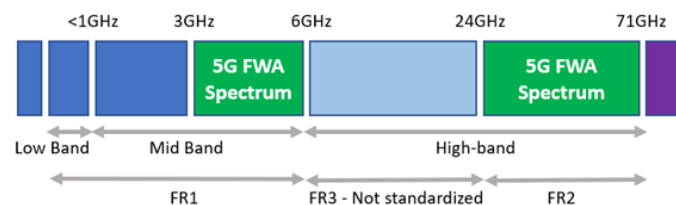

Figure 1: 5G FWA spectrum across 5G NR bands FR1 and FR2, with FR3 lower high-band under study.

The Broadband Forum’s TR-507 architecture provides a framework for this model. A single 5G FWA connection into the property acts as shared backhaul for the building. InCoax MoCA Access then distributes that capacity over existing coax to each apartment.

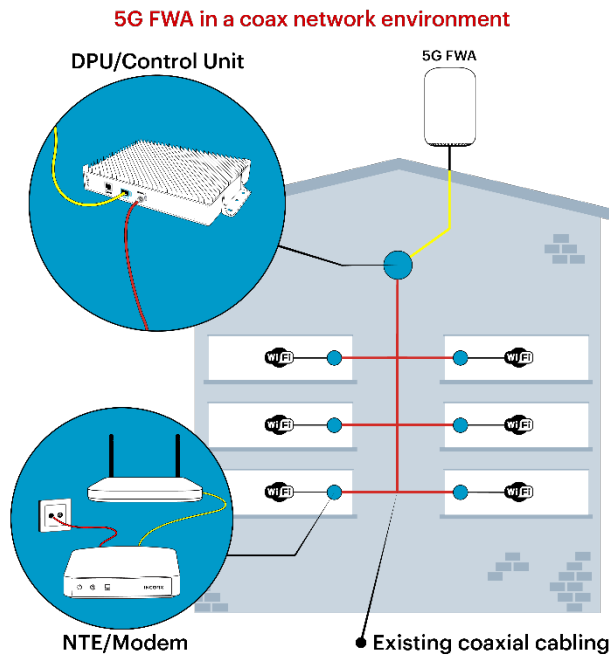

Figure 2: InCoax MoCA Access extends a shared 5G FWA connection over existing in-building coax infrastructure, from the DPU/control unit to apartment NTE/modems.

This building-centered approach was demonstrated at Network X in Paris, where Nokia and InCoax presented a multi-tenant 5G FWA solution based on TR-507 and MoCA Access over coax. The implementation received the “FWA Solution of the Year” award, highlighting that the concept is not only a technical architecture but a practical deployment model for real MDU environments.

For operators, the value is direct. Shared mmWave FWA can bring high-capacity broadband to a property quickly. InCoax MoCA Access can then distribute that capacity through infrastructure that is already installed. This reduces the need for full in-building rewiring, shortens deployment time and creates a faster route to customers in apartment buildings, student housing and other dense living environments.

The model also preserves a migration path. The same in-building MoCA Access platform can initially be fed by 5G FWA and later by fiber once fiber reaches the address. Operators can therefore accelerate service availability today without creating a dead-end architecture for tomorrow.

Craig Thomas, CEO and President of Broadband Forum, describes the industry challenge and the role of TR-507 in connecting 5G FWA to the in-building network this way:

“The industry has learned that the real challenge for high-band 5G is not reaching the street, but the last stretch inside the building. TR-507 answers that challenge by treating 5G FWA as shared backhaul to the MDU and using established in-building media such as coax to reach every apartment. The work demonstrated together with InCoax and Nokia shows how this approach can turn 5G FWA into a scalable broadband option for apartment buildings, rather than a technology that stops at the façade.”

Jakob Tobieson, CEO of InCoax Networks, sees the same issue as a practical deployment problem rather than a limitation in 5G radio performance alone:

PRESS RELEASE

July 9, 2026

“The missing piece in many 5G FWA deployments is not radio capacity alone, but a practical way to take that capacity from the outside to every apartment. By reusing existing coax with MoCA Access, InCoax makes shared 5G FWA deployable in MDUs without the delay and disruption of rewiring. That is where we believe our technology can help turn 5G into real broadband service.”

The wider implication is clear. Fixed wireless access is already one of 5G’s most commercially relevant use cases, but dense MDU markets remain hard to serve because full fiber upgrades inside existing buildings can take years. A building-centric architecture where 5G FWA feeds the property and InCoax MoCA Access reuses the existing coax network removes much of that delay.

In that light, the search for a dramatic 5G breakthrough may have overlooked a simpler answer. One of the most meaningful roles for 5G mmWave may be shared, high-capacity broadband access to dense buildings. It addresses a clear market problem, fits operator economics and can be deployed without waiting for fiber to reach every apartment.

Sometimes the most important shift in a technology cycle is not a brand-new application. Sometimes it is a better way to apply the tools that are already available.

For a deeper technical description of the architecture, including the role of TR-507, MoCA Access and in-building coax, download the whitepaper [Extending 5G FWA to MDUs over coax with InCoax and BBF TR-507](#).

For more on InCoax work on sustainability and cost savings in brownfield buildings, download the whitepaper [Enhancing MDU broadband sustainability with MoCA Access technology](#).

The information was submitted for publication, through the agency of the contact person set out below, at 11.30 CEST on July 9, 2026.

For additional information, please contact:

Jakob Tobieson, CEO, InCoax Networks AB

jakob.tobieson@incoax.com

+46 (0) 764 955 260

About InCoax Networks AB

InCoax Networks AB (publ) re-purposes existing property coaxial networks in fiber and fixed wireless access (FWA) extension deployments for Communication Service Providers (CSP) globally.

The technology is a high performance, future proof, reliable and cost-effective complement, that reduces installation time and improves take-up rate, to boost digital inclusion and Internet access for all.

www.incoax.com

To keep updated on corporate information, visit incoax.com. Vator Securities AB, tel. +46 8-5800 6599, ca@vatorsec.se, is acting as the company’s Certified Adviser.